



PAL

PAL – Corporate Presentation
Assembly Line Automation

Patil Automation Ltd.

(Formerly Known as Patil Automation Private Limited)

www.patilautomation.com

ABOUT US



PAL is an India based Automation Company. From specialized welding assembly line, assembly line automation, & machine builder, PAL continues to drive forward-thinking tech solutions and improve production line efficiencies for the automotive industry and offer round-the-clock service support.

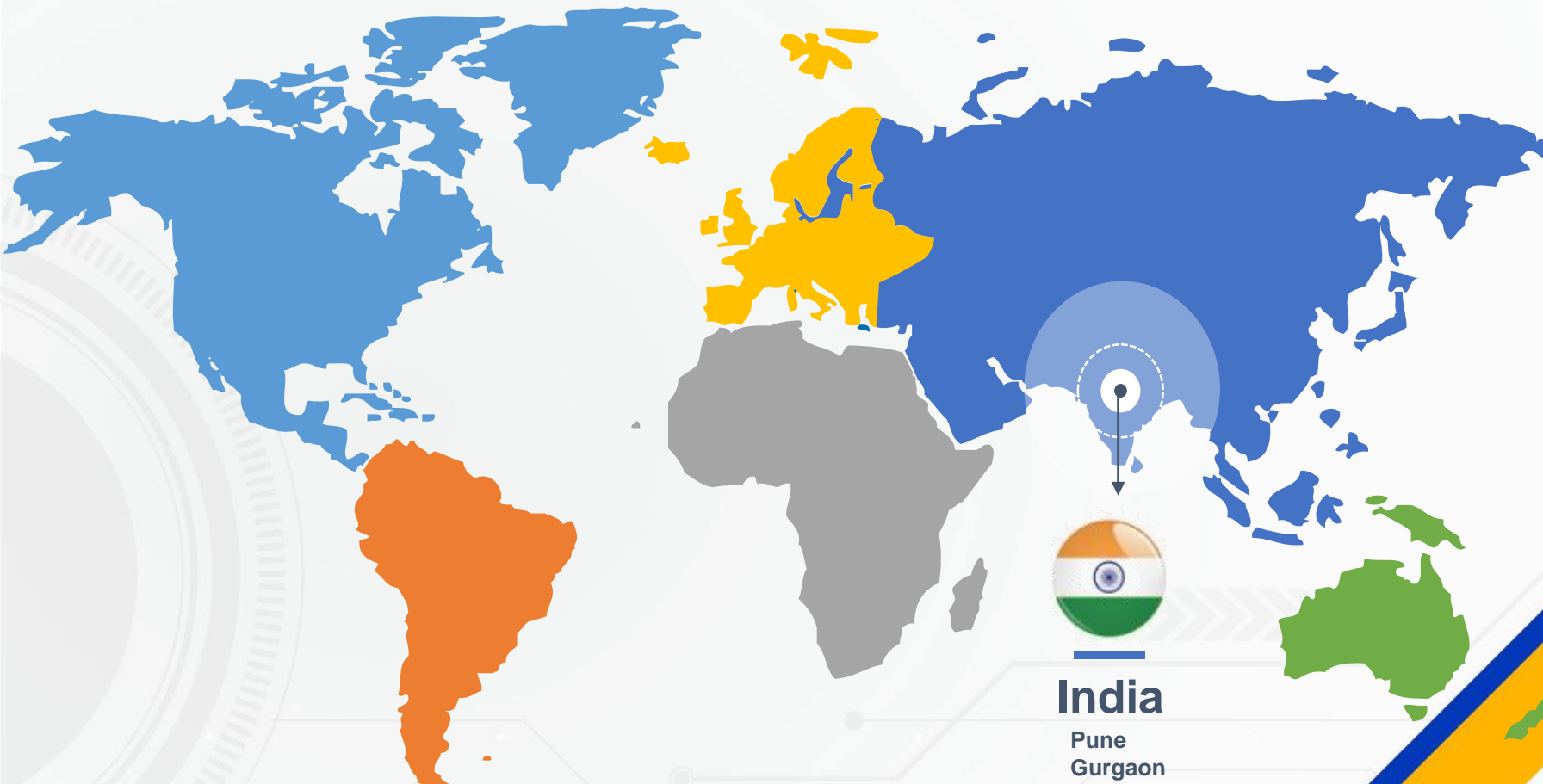

A
B
O
U
T
U
S

ABOUT US



OUR PROCESS

PAL offers a complete, one-stop automation solution for the automotive industry. From first contact to after-sales support, our team ensures that customers get the specialized machines and service they need.

This is what you can expect from our process:



CONCEPT AND DESIGN



PROGRAMMING

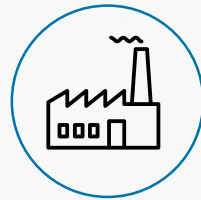

MANUFACTURE

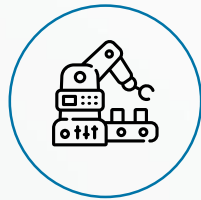

ASSEMBLY



COMMISSIONING



INSTALLATION



TRAINING



AFTER-SALES SERVICE

OUR SERVICES



POWERTRAIN ASSEMBLY SYSTEMS

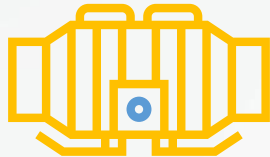

CATALYTIC CONVERTER ASSEMBLY SYSTEMS

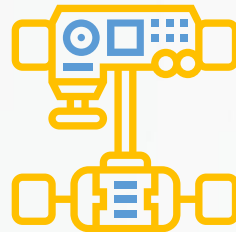

ELECTRIC VEHICLE ASSEMBLY SYSTEMS



NON-AUTOMOTIVE



DESIGN SERVICES

- Weld Automation
- Line Automation
- Handling Automation
- Special Purpose Machines
- IOT Projects

ABOUT US



OUR SERVICE OFFICES



- Weld Automation
- Line Automation
- Handling Automation
- Special Purpose Machines
- IOT Projects

ABOUT US



GLOBAL FOOT PRINT



Projects Delivered

- India
- Poland
- Colombia
- Russia CZ
- Mexico
- Germany
- Thailand
- France
- Bangladesh
- South Africa

- Weld Automation
- Line Automation
- Handling Automation
- Special Purpose Machines
- IOT Projects

ABOUT US



MAJOR FACILITIES



Sales & Marketing



**Mechanical &
Control Design Team**



**Design Simulation
Team**



**Robot Teaching &
PLC Programming**



**In house Engg. Facility
Quality Control
Project Management & Assembly
Customer Service & Support**



**2D LASER Cutting
Machine**



VMC



**CNC
Bending
machine**



**Plasma
Cutting
Machine**

DESIGN, SIMULATION AND INTEGRATION CAPABILITIES

S.N.	Description	Remark
1	Dedicated Application Engineering team for detail working on RFQ in terms of Process study, Cycle time calculation, Line layout design, Line layout optimization	8 Nos. (Mechanical) 4 Nos. (Controls) 2 Nos. (Simulation)
2	Three team in mechanical design Catia Team Solid Edge Team 2D design release team	30 Nos. (Catia Design Engineer) 28 Nos. (Solid Edge Design Engineer) 51Nos. (Solid Edge Design Engineer) 18 Nos. (2D Design Engineer)
3	Robot Simulation Software Process Simulator Delmia Yaskawa Moto seam ABB Robot studio Panasonic Robot simulation	7 Nos. Simulation Engineer

ABOUT US



DESIGN, SIMULATION AND INTEGRATION CAPABILITIES

S.N.	Description	Remark
4	<p>Robot Programming Our Engineer are capable to integrate all Robotic Applications. By using below robots, Yaskawa, Fanuc, Panasonic, Kuka, ABB, OTC, Kawasaki, Nachi</p>	<p>Robot Programmer At PAL : 38 Nos. On site : 15 Nos.</p>
5	<p>PLC Programming Our Engineer are capable to integrate all PLC System available Mitsubishi, AB, Siemens, Omron, Proface, LG etc.</p> <p>Offline programming during design Phase Standard PLC Programing module</p>	<p>PLC Programmer : 64 Mitsubishi : 52 Nos. AB : 4 Nos. Siemens : 6 Nos. Omron, Proface : 2</p>

POWERTRAIN ASSEMBLY SYSTEMS

PAPL builds automotive assembly systems and production lines for all aspects of the powertrain system, including:

Vehicle Assembly | Seat Assembly | Axle Assembly | Engine Assembly |
Transmission Assembly

Every solution is designed to meet specific customer requirements and PAPL strives to deliver the right fit for a particular market - offering a range of manual, semi-automated and fully automated solutions.

POWERTRAIN ASSEMBLY SYSTEMS



PAL builds automotive assembly systems and production lines for all aspects of the Automotive system, Every solution is designed to meet specific customer requirements and PAL strives to deliver the right fit for a particular market – offering a range of manual, semi-automated and fully automated solutions.

Complete Assembly Line

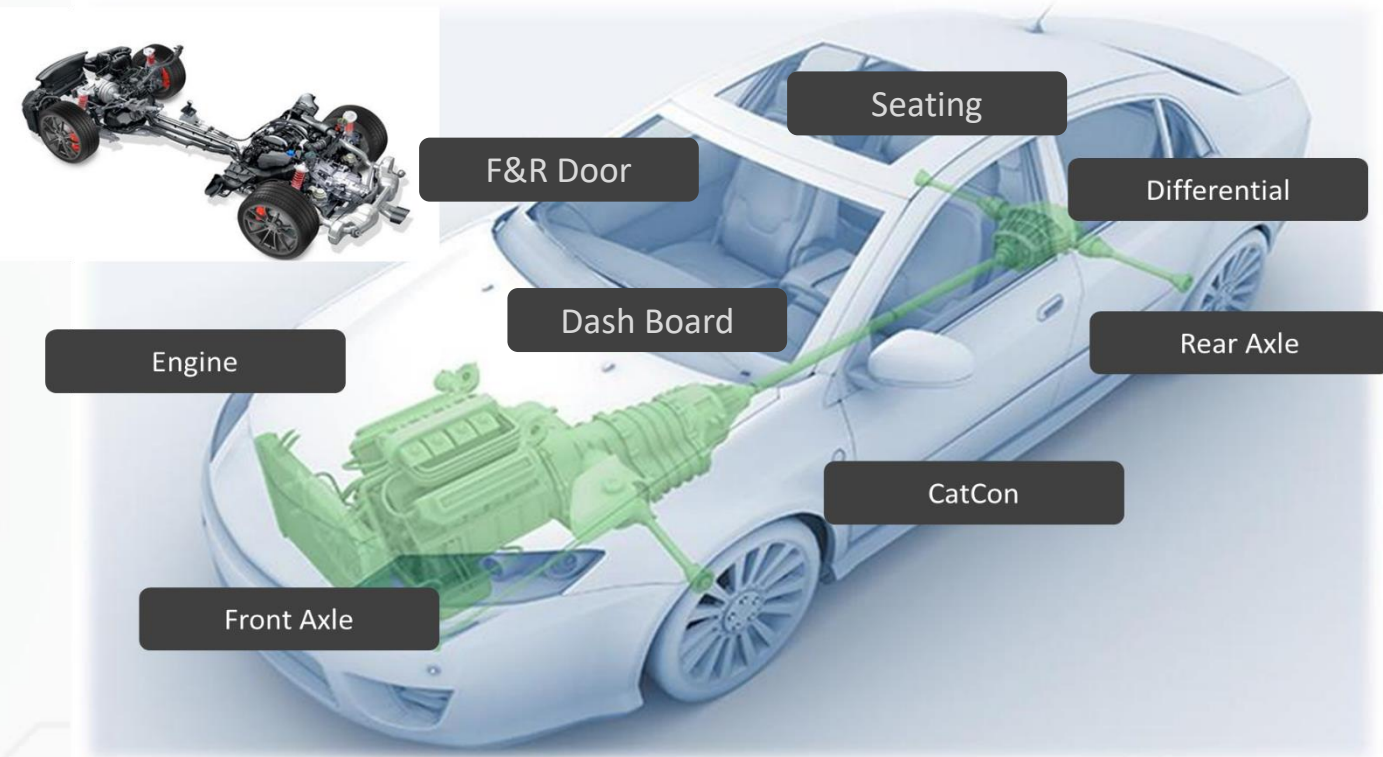

VEHICLE ASSEMBLY SYSTEMS



With innovation at the forefront of everything we do, the concepts we develop and projects we deliver on are nothing short of extraordinary. Our products meet the demands of the complex two wheeler assembly process and ensure the flexibility to meet the needs of our individual customers, while attaining a high level of quality and safety.

PAL has years of experience in Two Wheeler assembly line, from standalone machines to complete assembly lines. As the two wheelers are evolving from IC to EV, so is our technology, while keeping the modularity.

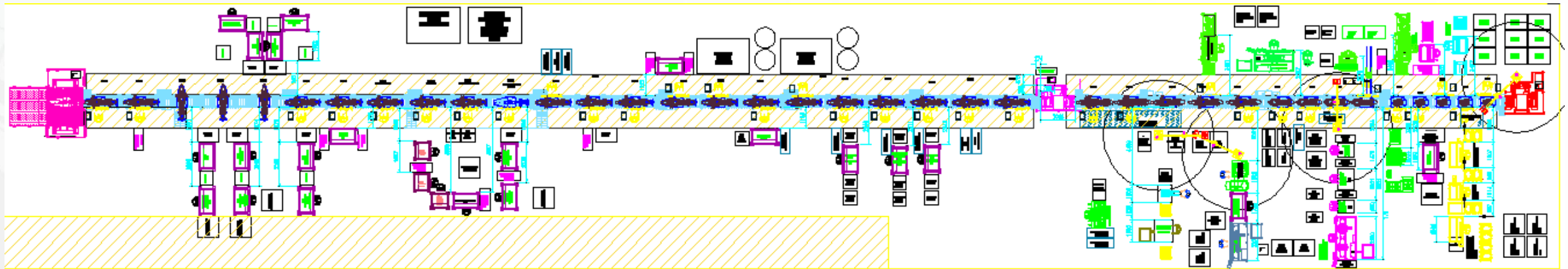

Vehicle Assembly Line, Layout :- 110m x 16m
Piaggio, Pune

PIAGGIO VEHICLE ASSEMBLY LINE

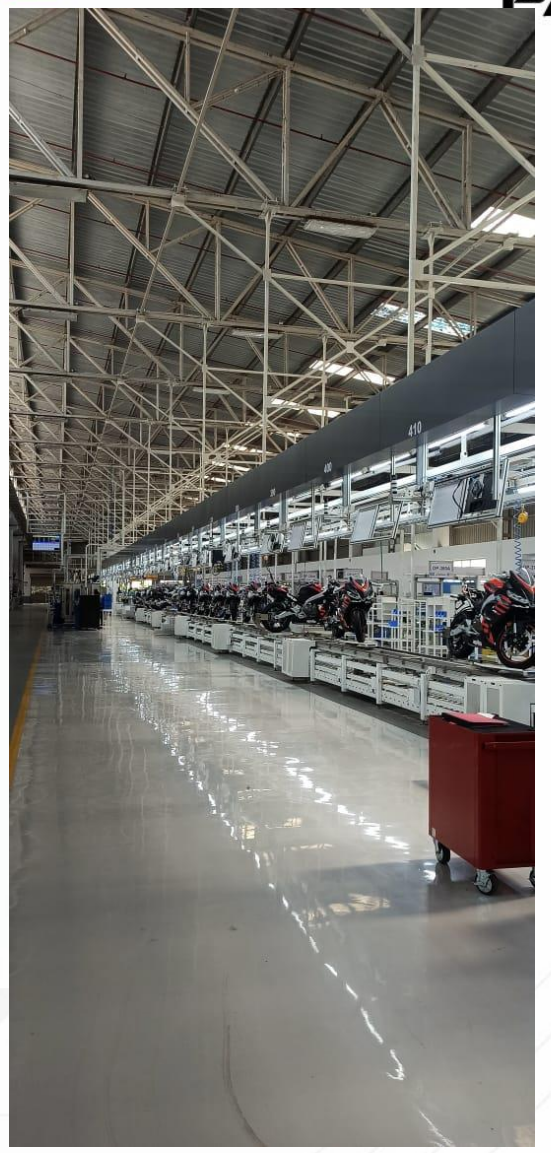

PIAGGIO VEHICLE ASSEMBLY LINE

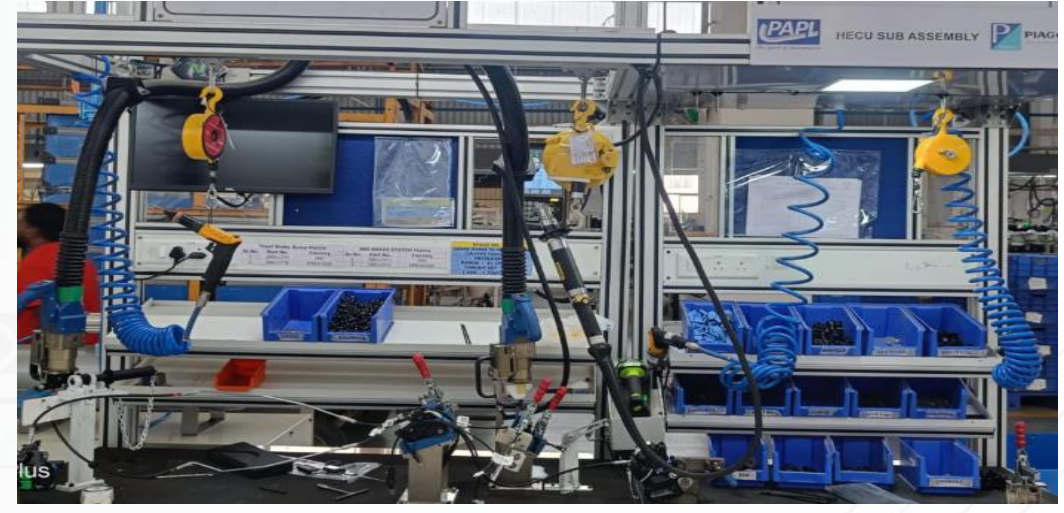
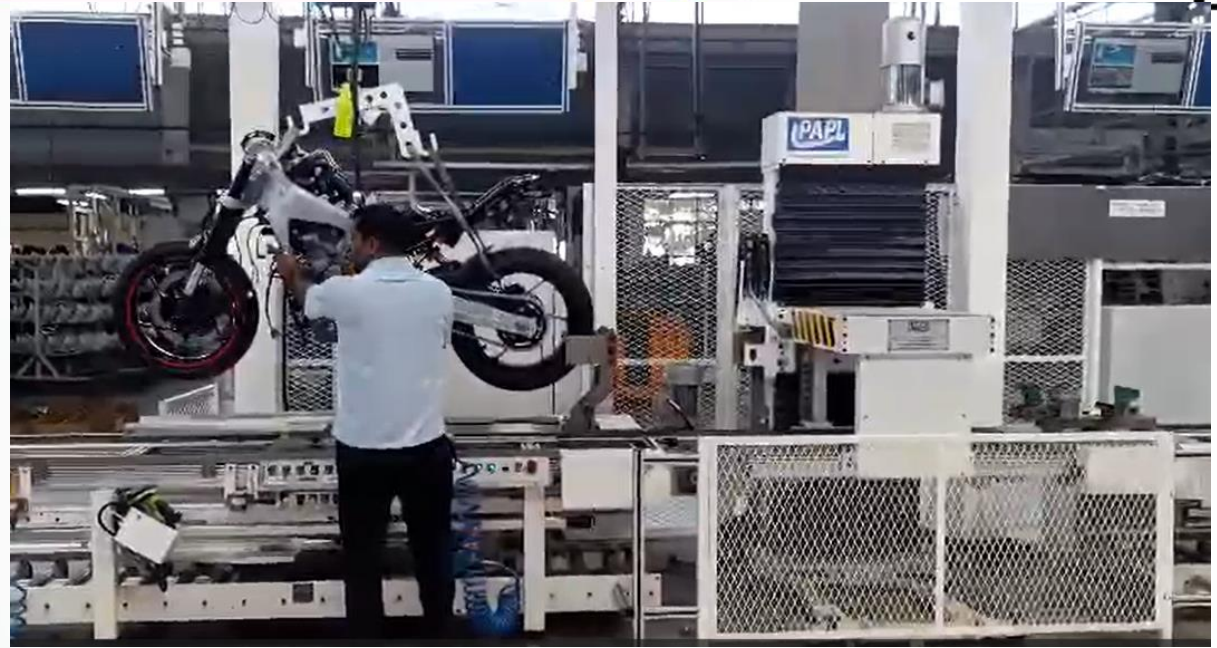

Shot on OnePlus
2024.02.09 13:56
By Rohit

DT2 HCU ASSEMBLY LINE



Supply for Semi Auto HCU Assembly Line,
TACO Punch Powertrain, Pune
Assembly Line - Common for 2 Variants,

- Pressing & Tightening Station,
- Tightening with Auto Screw feeder,
- Vision check,
- Powered Conveyor,
- Operator guidance using SCADA System,
- Traceability and Conformity using SCADA System

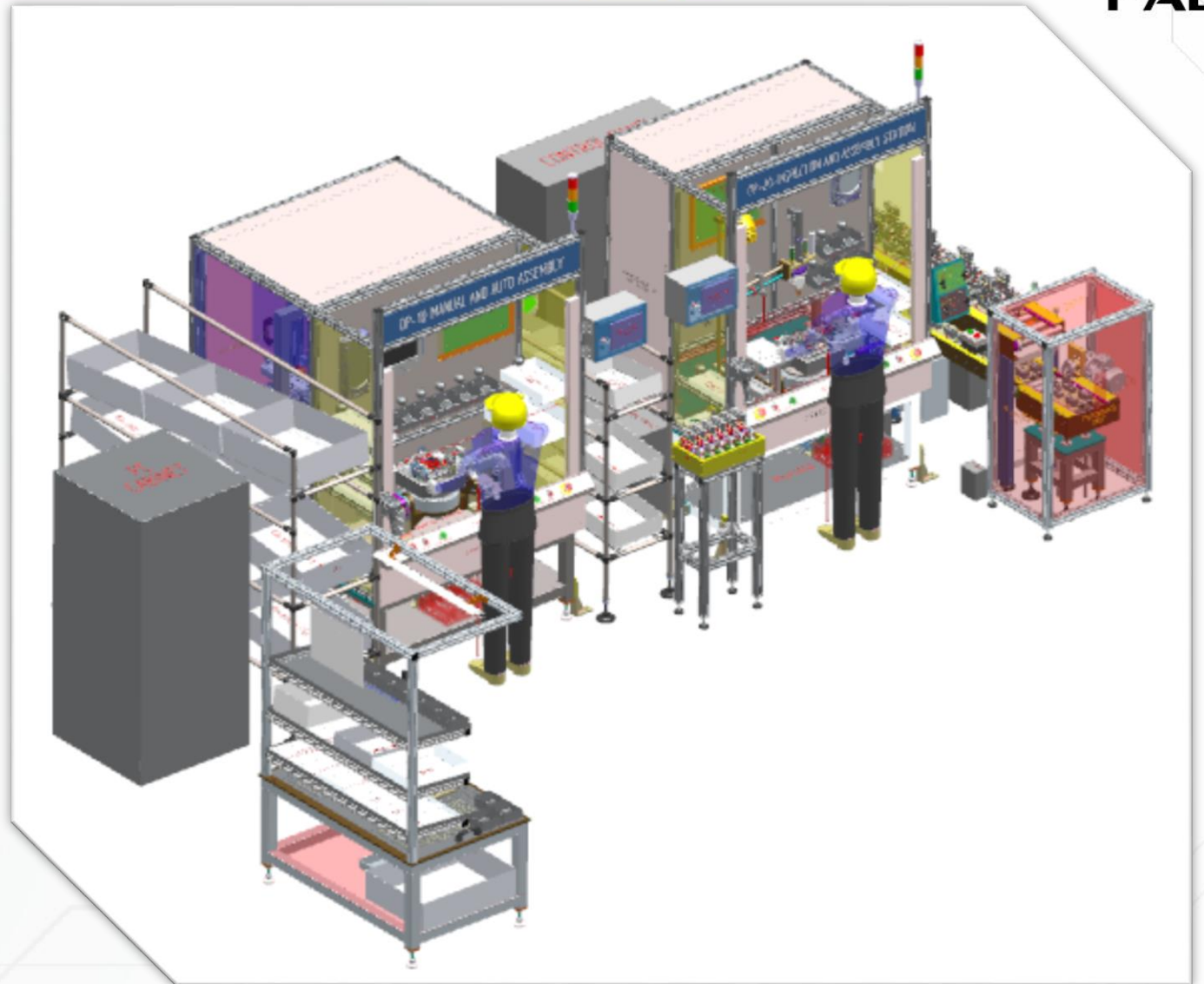

DT2 HCU ASSEMBLY LINE

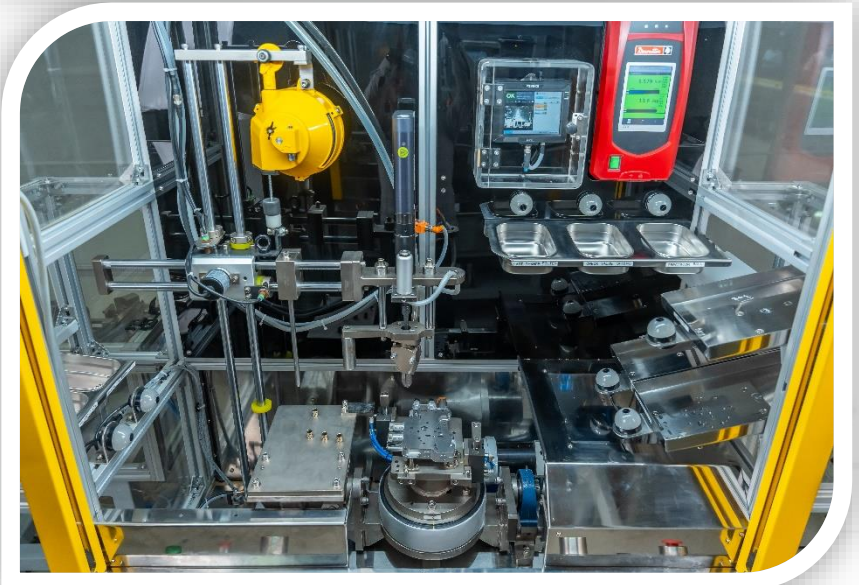
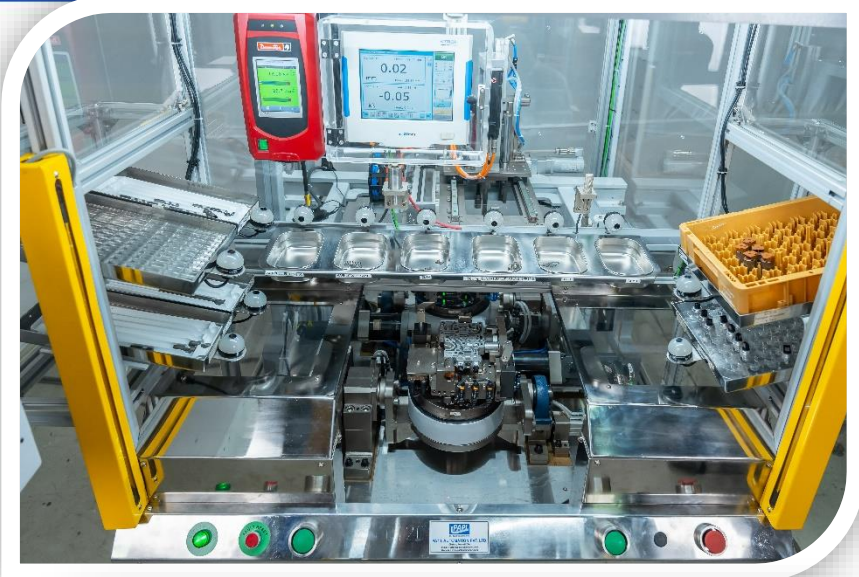

DOOR TRIM ASSEMBLY LINE

Supply for Door Trim Assembly Line,
Krishna Maruti, Kharkhoda

Assembly Line - Common for 2 Variants,

1. Assembly Stations
2. Auto-Pop Up fixture – 2 Variants
3. End of Line Inspection
4. Traceability & Conformity
5. Scada System – Operator Guidance

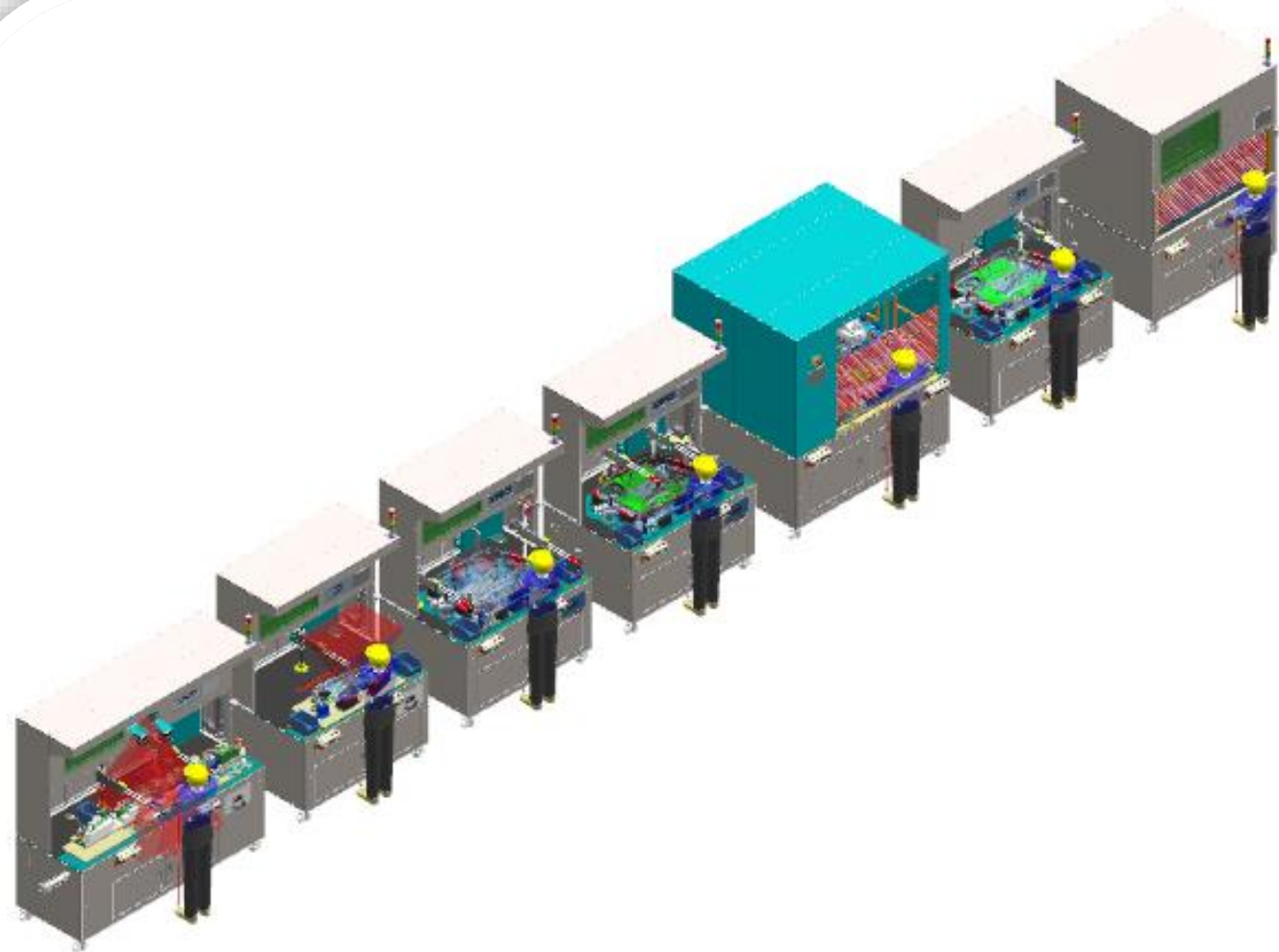

DOOR TRIM ASSEMBLY LINE



SEAT ASSEMBLY LINE



Supply for Seat Assembly Line,
Krishna Maruti, Kharkhoda

Assembly Line - Common for 1 Variants,

1. Seat Frame Assembly Line Conveyors
2. Material Handling
3. Robotic - Pick and Place
3. End of Line Inspection

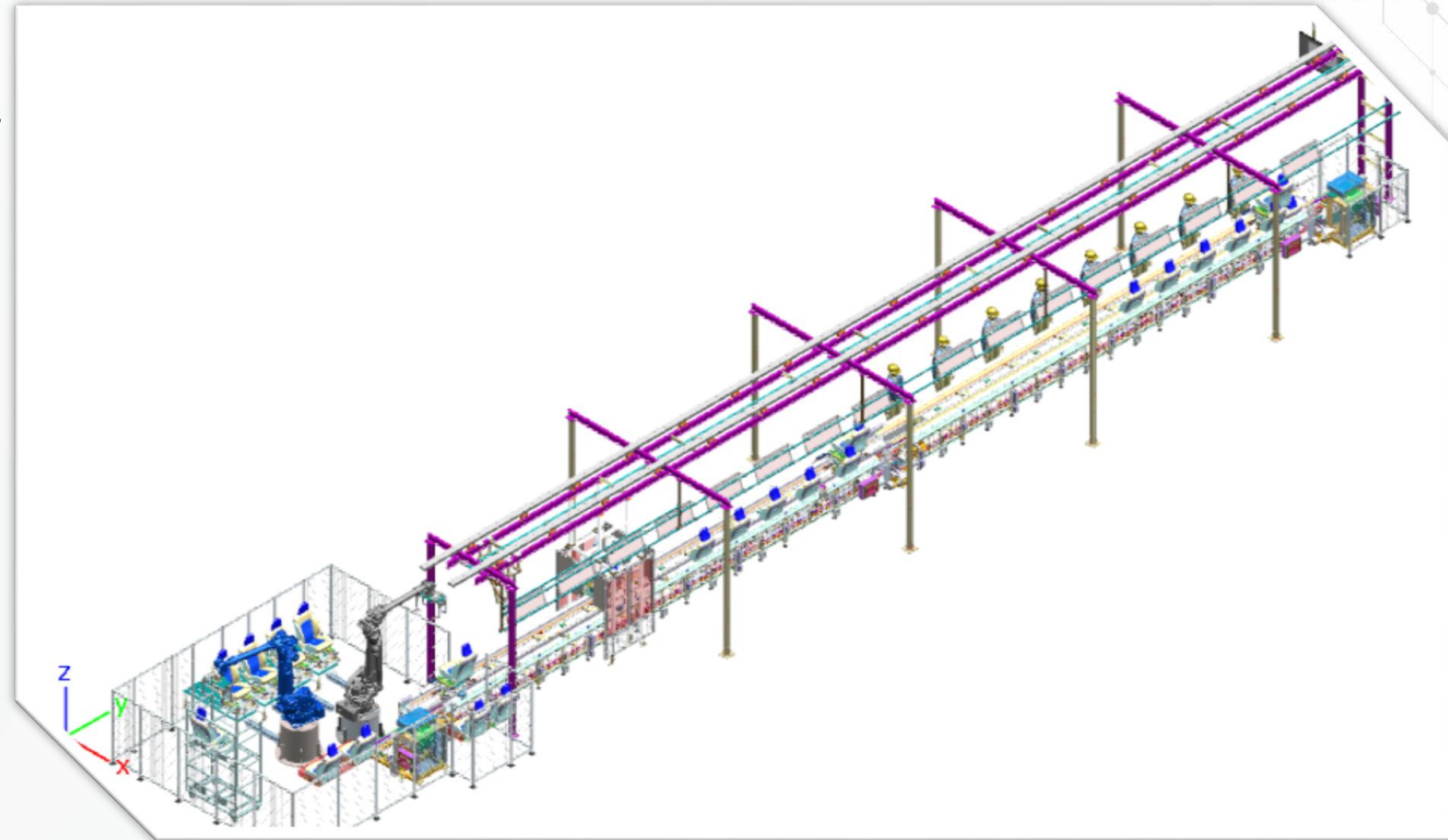

SEAT ASSEMBLY LINE



Seat Frame Assembly Line
Conveyors
Material Handling
Pick and Place
End of Line Inspection



Assembly Line Conveyors
Bowl Feeders,
Pick & Place
Material Handling
Vision inspection
End of Line Inspection

Complete Automated Assembly & Inspection Line Conveyor

SEAT ASSEMBLY LINE



Seat Frame Assembly Line
Conveyor
Material Handling
Pick and Place
End of Line Inspection



Power and free conveyor
Lifter arrangement at both the ends of conveyor.
Pick and place gantry and the end of conveyor for unloading the component.
Assembly pallets
Marking station

AUTOMECH 2WD & 4WD FRONT ASSY LINE



4WD Front Sub Assembly Line
Motorized Return Line Conveyor
Tightening and Torqueing

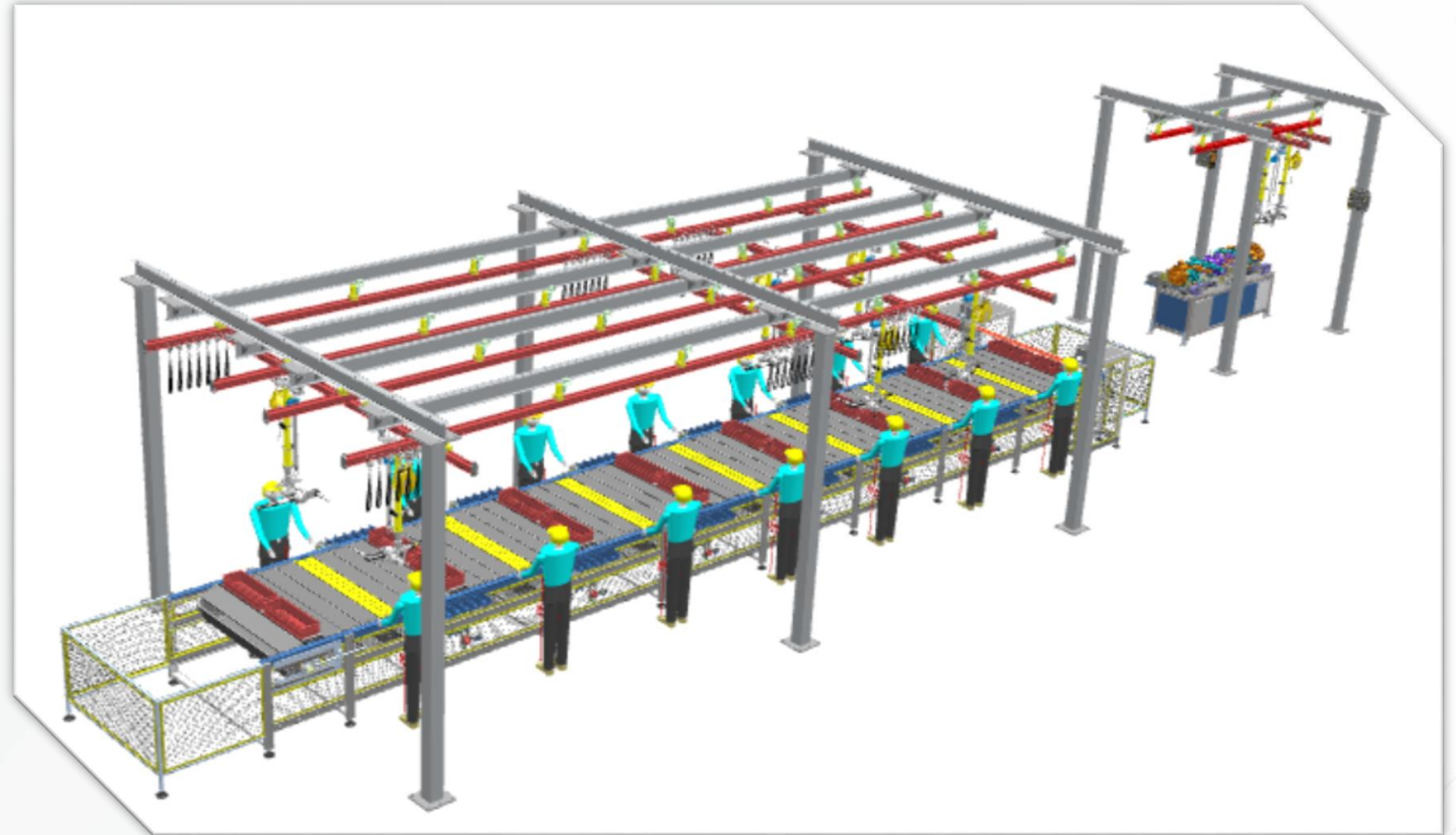

Automech, Nashik 2WD & 4WD Front Sub Assembly Conveyor

GEAR BOX ASSEMBLY LINE



Complete Turn Key scope of Supply for Semi Automatic Gear Box Assembly Line, Piaggio Pune

Assembly Line - Common for 2 Variants

- Hydraulic Press
- Shim Detection SPM
- Leak Testing SPM
- Assembly Trolleys
- Inspection Station

AXLE SHAFT & CYL HEAD ASSEMBLY

Sub Assembly Line for Axle Shaft Assembly: -

This is Palletized Sub Assembly Line consisting of online & offline

- SERVO PRESS machines,
- Greasing Station,
- Hydraulic Press Machines
- DCNR Station



Cylinder Head & Crankcase DISC / CUP Plug Assembly Line

This is Palletized Sub Assembly Line consisting of online & offline

- SERVO PRESS machines,
- Robot for Positioning
- Hydraulic Press Machines with Load cell
- Traceability



DISPENSING & VISION INSPECTION

Sealant Dispensing & Oil Spraying Machines: -

Sealant Special Purpose Machine for Oil Sump & BIW Parts

- Servo Sliding arrangement for Sealant Gun
- Multimodal JIGS concept
- Six Axis Robot For Position
- DCNR Station



Vision Inspection Station & Pick to Light System

Auto Inspection Station with Vision camera for Inspection & Measurement

- Auto Inspection for Vision camera
- Pick to light system for error-proof assembly lines
- Auto checking with Traceability (Laser Marking)



OIL PAN ASSEMBLY LINE

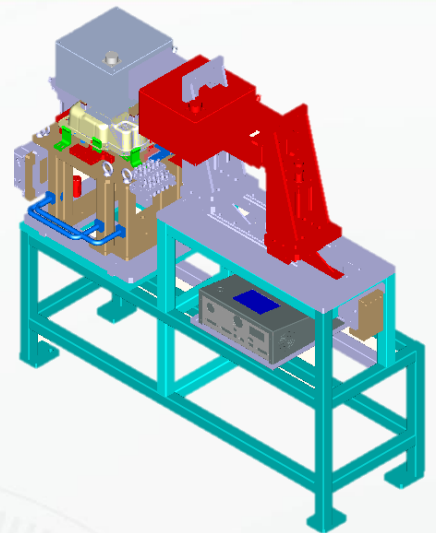

Robotic Oil Pan Assembly Line
Press Machine
Tightening Machine
Robotic Handling

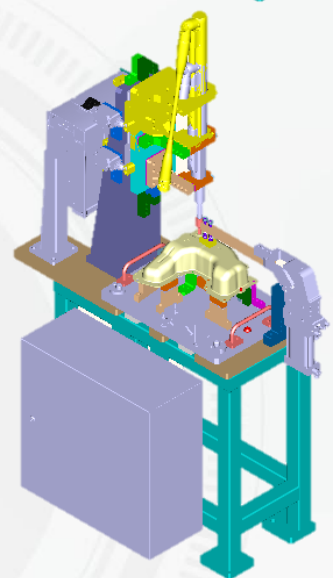

Tightening Machine

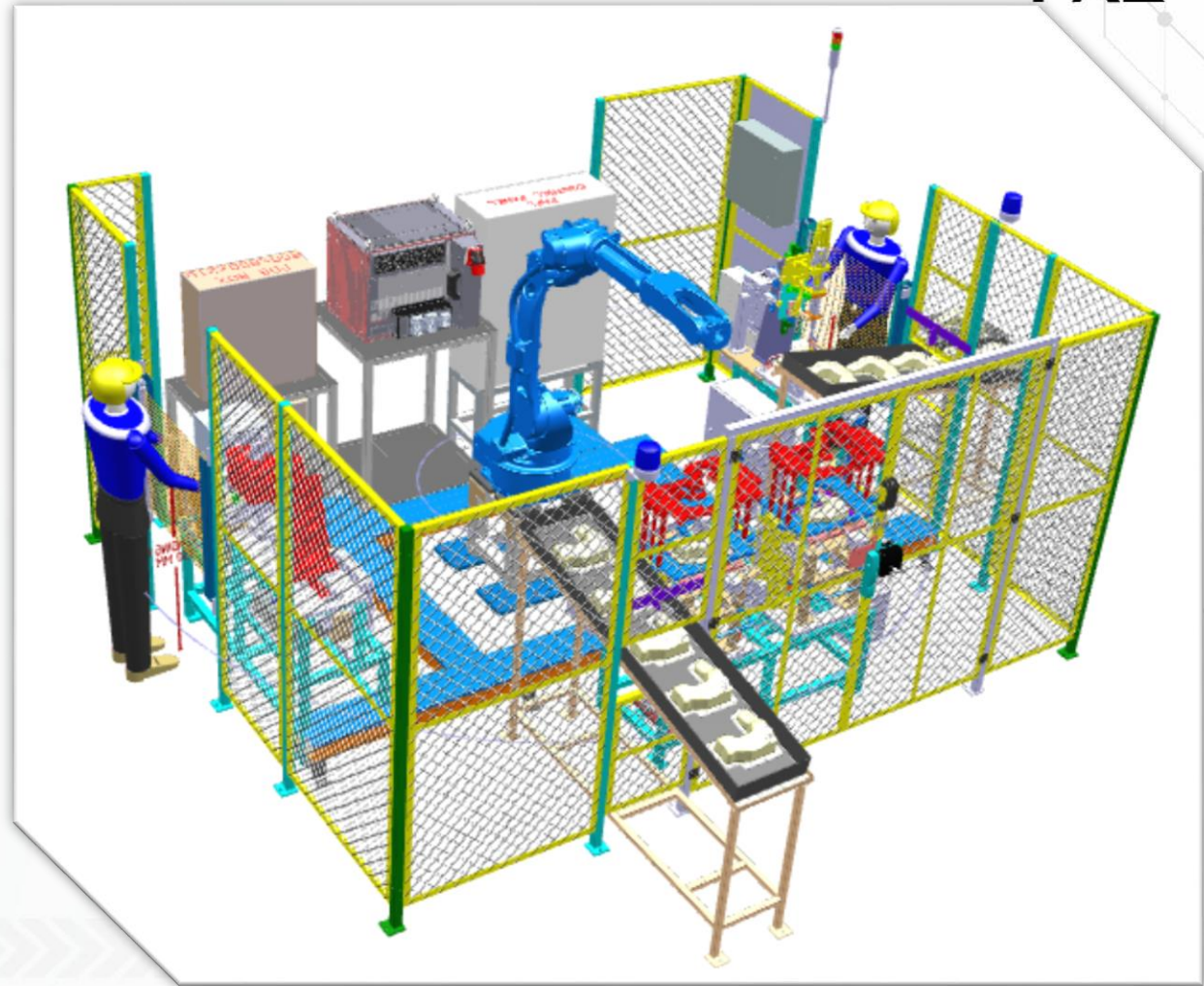
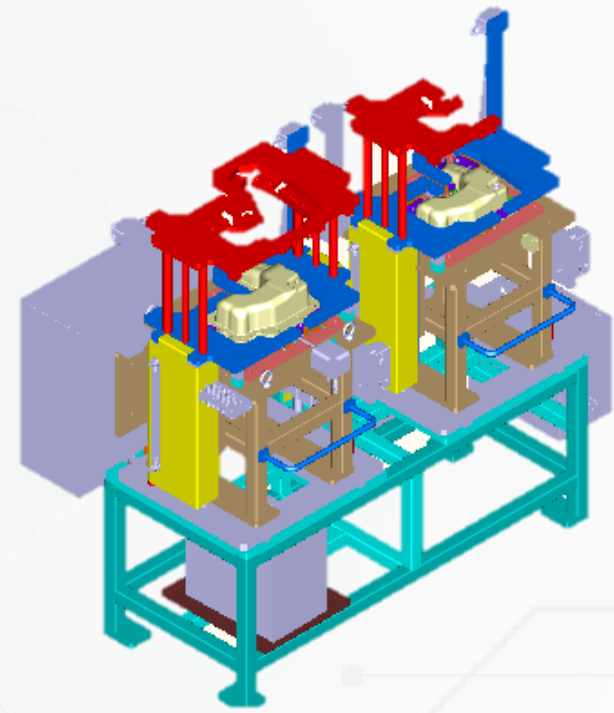

FUEL TANK ASSEMBLY LINE

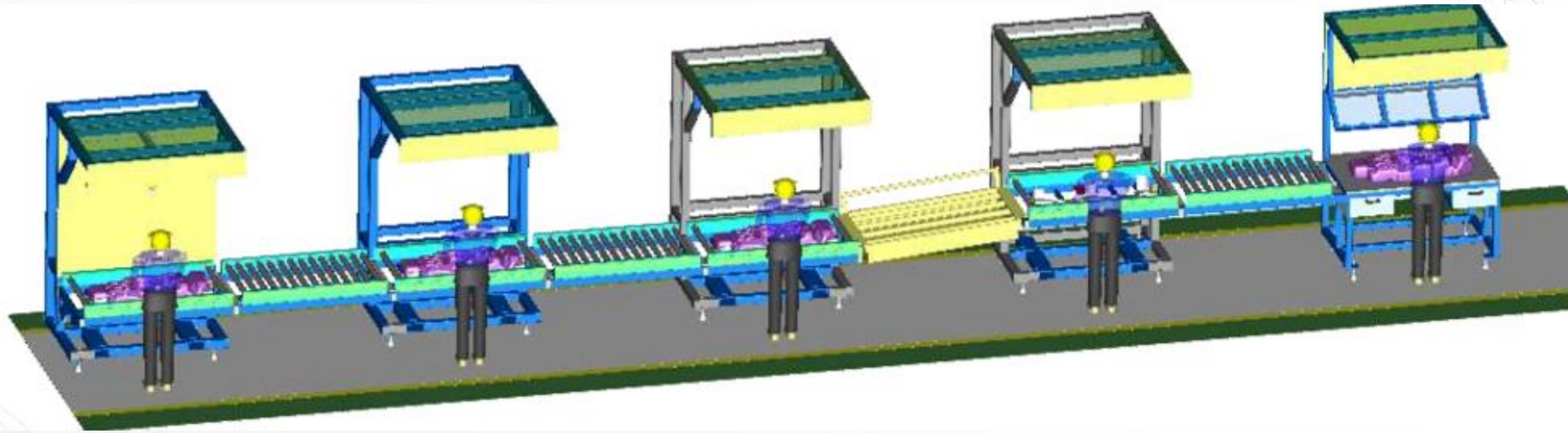

Complete Turn Key scope of Supply for Fuel Tank Assembly Line,

- Pump Fitment in Fuel Tank
- Harness Fitment in Fuel Tank
- Leak Test SPM
- Conductivity Check SPM
- Visual Inspection
- Tractability System and SCADA System

DOOR PANEL ASSEMBLY LINE

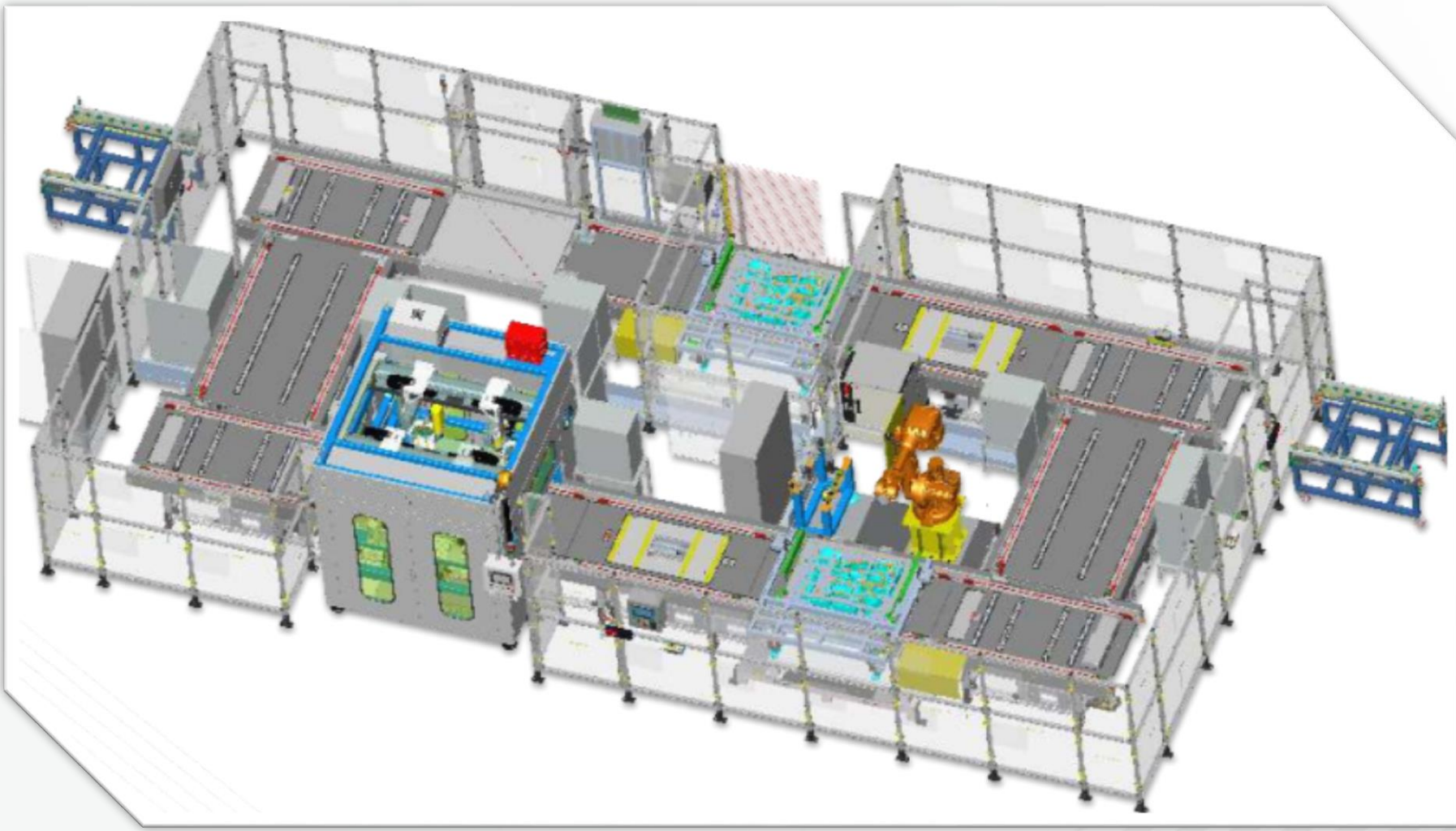

Door Panel Assembly Line
Forvia, Pune

PIPE BENDING CELL



Complete Turn Key scope of Supply for Full Automatic Pipe bending
Pipe Hopper
Pipe Segregation
Pipe Seam Detection
Pipe inside Greasing
Hydraulic Pipe Notching
Hydraulic Pipe Swaging
Hydraulic Pipe Flaring
Automatic Pipe Bending
Automatic Part unloading
Pipe Handling Robot
Pipe Holding Gripper
SCADA System

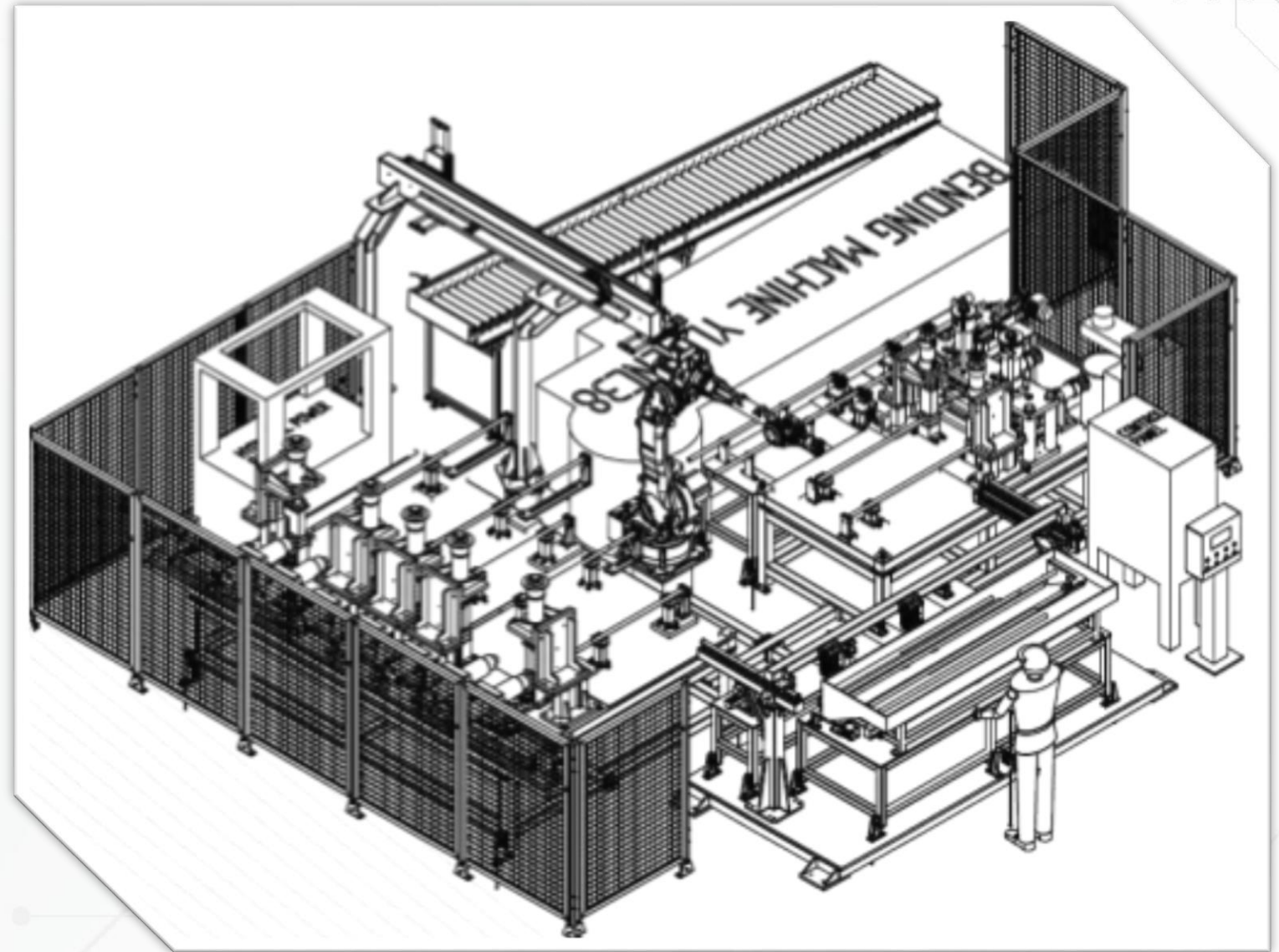



E
L
E
C
T
R
I
C

V
E
H
I
C
L
E

ELECTRIC VEHICLE ASSEMBLY SYSTEMS

Driven by the global movement towards cleaner and greener energy, automotive manufacturers are expanding their electric vehicle (EV) offerings. PAPT supports OEM customers in their quest for climate-friendly technologies by developing innovative battery pack and power electronics assembly systems.

EV ASSEMBLY SYSTEMS



Focus Areas

EV Component Assembly involves assembly of small sized intricate parts which are difficult to assemble and easy to forget. PAL has Mastered the art of solving this complexity by right use of Automation and Industry 4.0 solutions.

Traction Inverter

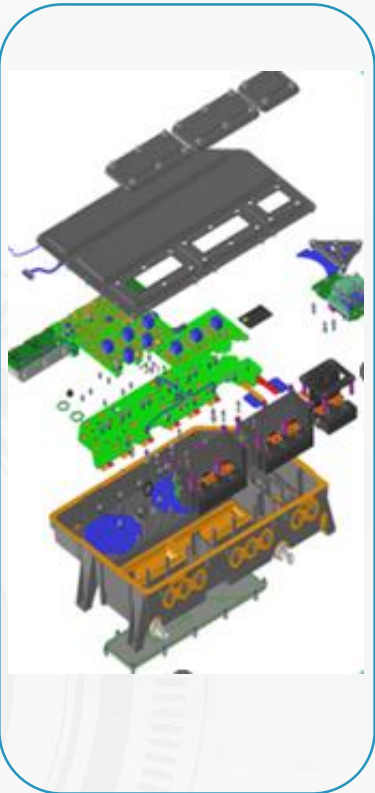

Battery Pack



Cylindrical cell



Prismatic cell



Pouch cell

Traction Motor



Hub Motor



Axial Flux Motor



BLDC Motor

MCU/VCU

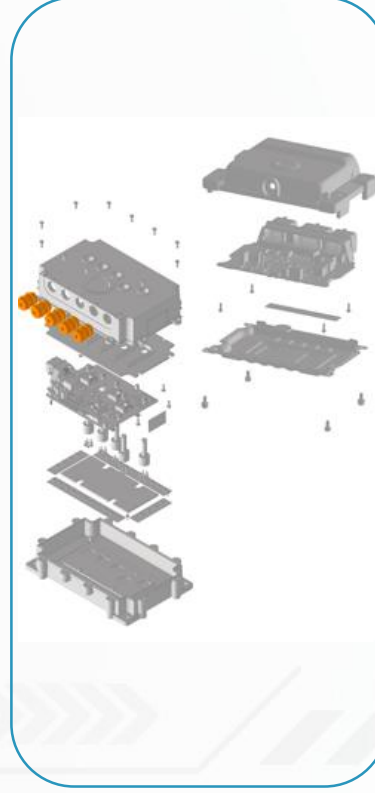

Gearbox

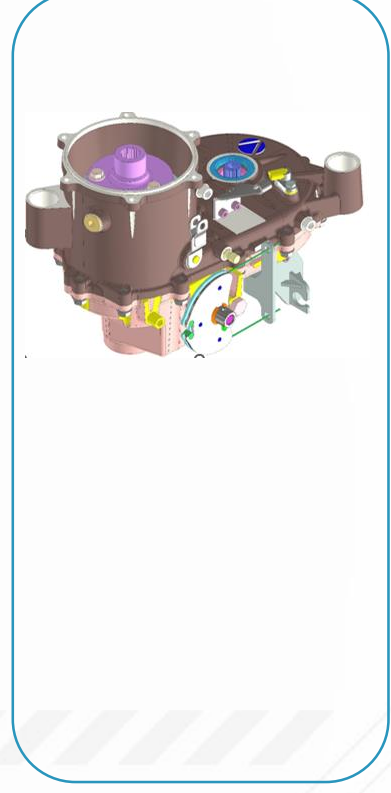

PRISMATIC CELL ASSEMBLY LINE



Complete Turn Key scope of Supply for
Semi Automatic EV Module Assembly
Line
SCADA System –
Traceability & Conformity

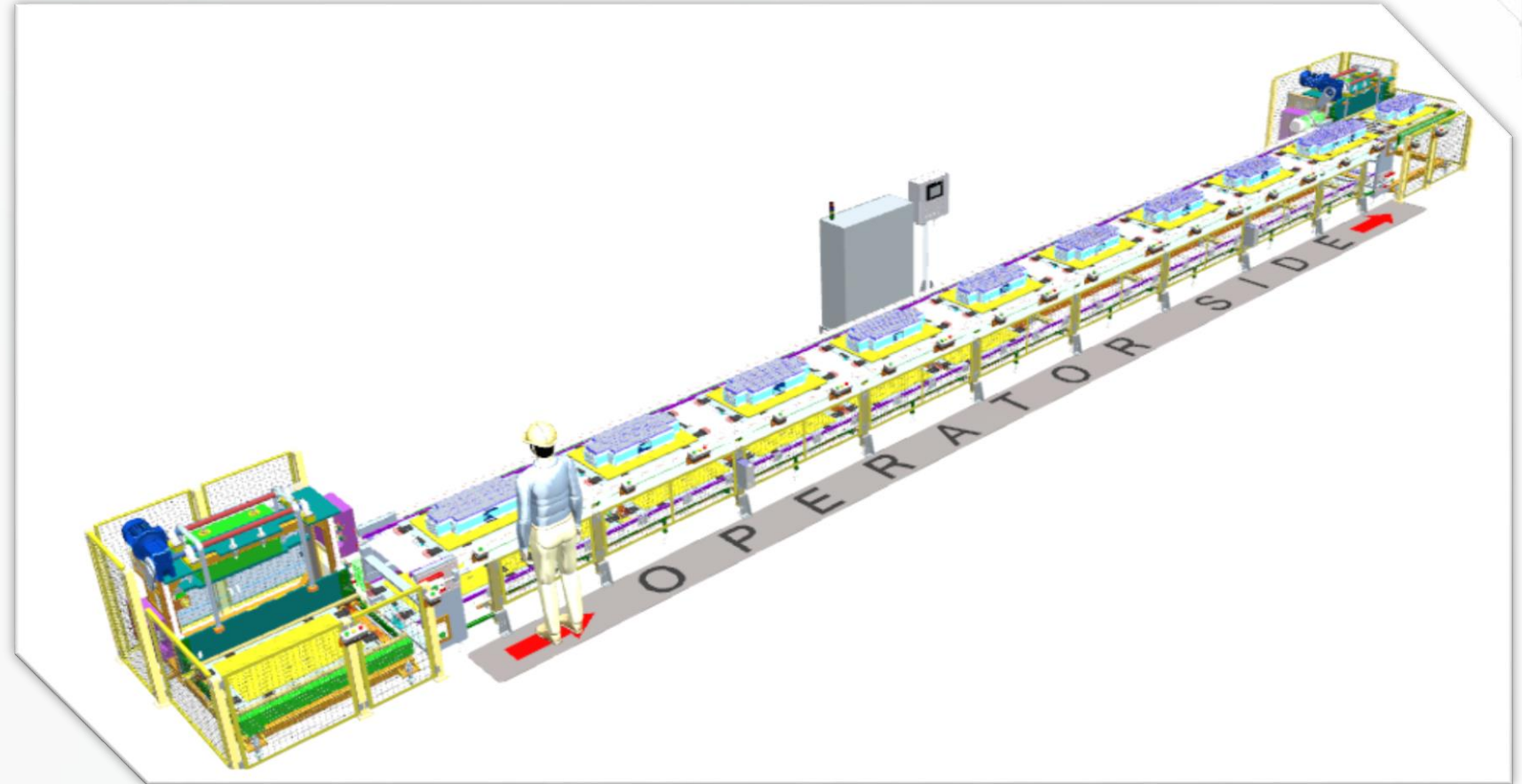

PRISMATIC CELL COMPRESSION MACHINE



Prismatic Cell Compression Machine
SCADA System –
Traceability & Conformity

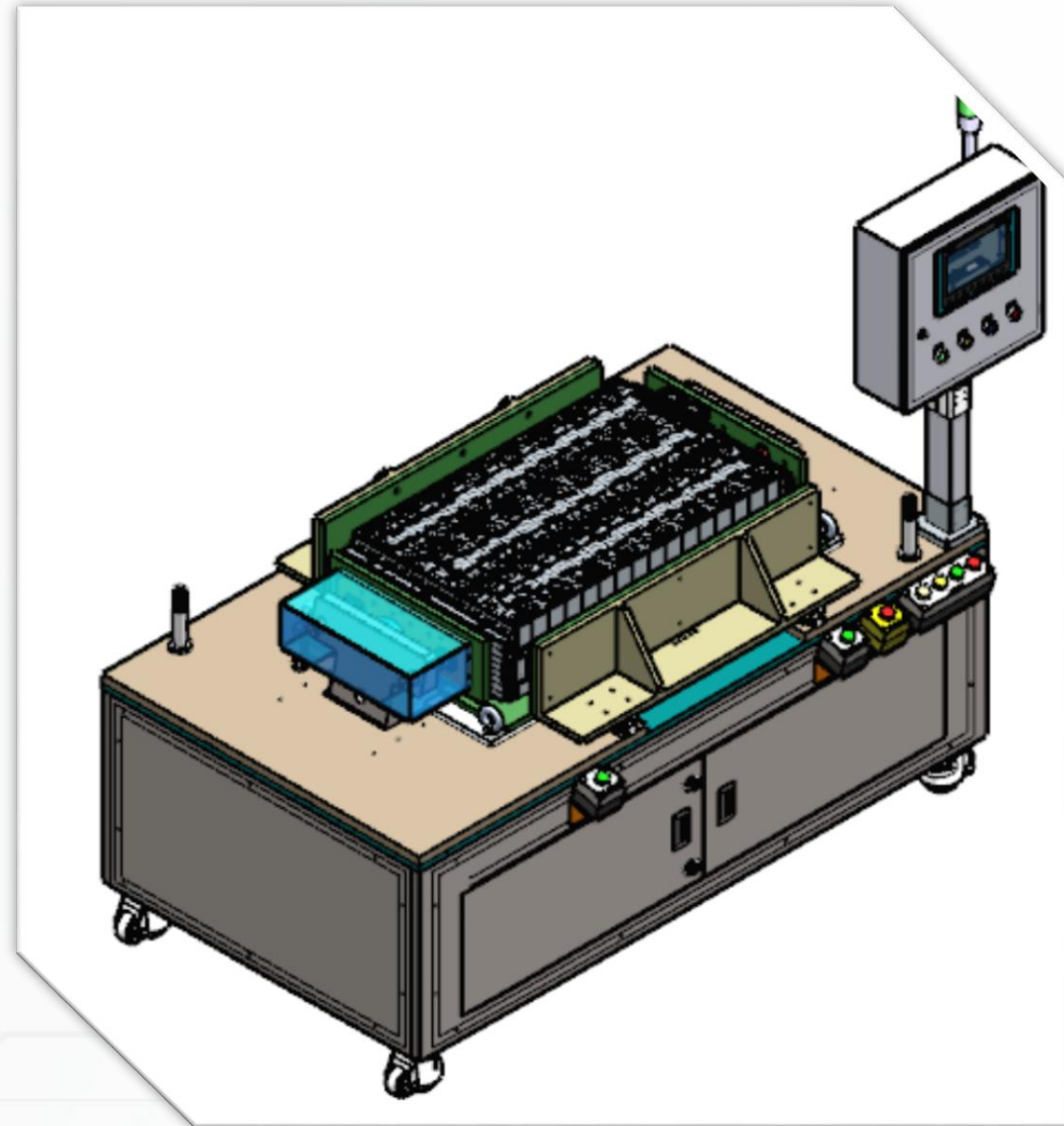

POWERED CONVEYOR ASSEMBLY LINE



PAL specializes in standardized Conveyors, adaptable to the customer's requirements.

Projects delivered all over India are a testament that the technology we deliver is of the highest quality and safety standards.

MSKH – Return line Conveyor (start –stop) along with Pallets designed to accommodate customer component.

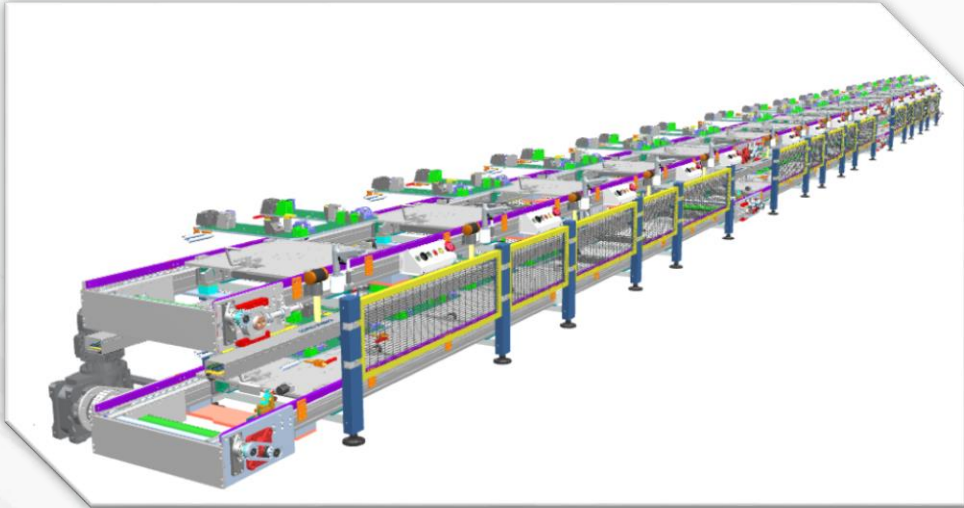

Schindler, Pune, Escalator Assembly Line Conveyor

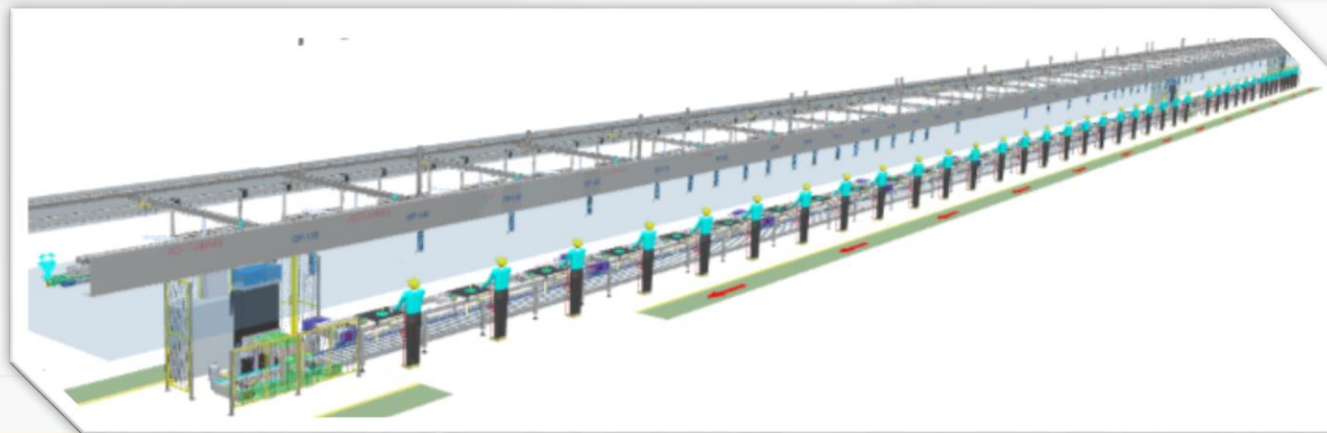
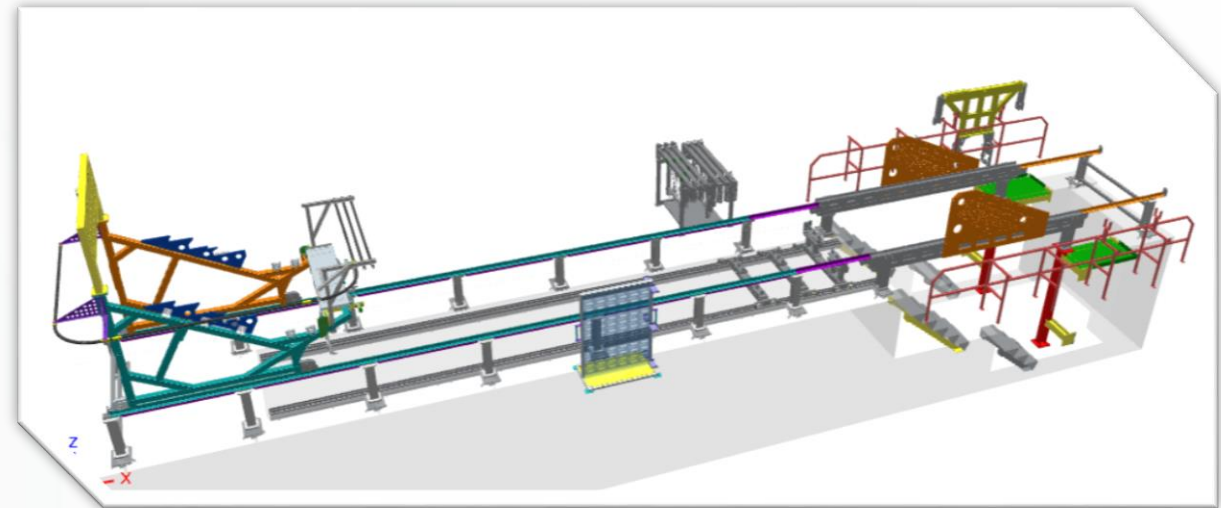

Piaggio Assembly Line –
Continuous moving Conveyor

SPECIAL PURPOSE MACHINE'S



PAL's range of standard machine can be configured in various ways on a production line to create a customized solution that meets the customer's exact specifications.

Plasma & gluing gun.
Handling robot for proper plasma & gluing of the component.
Safety fencing with mezzanine flooring, sliding doors, operator pendent, etc.



Automated assembly stations with inline quality inspection stations.
Feeding mechanism, trolleys/trays for input parts at individual stations.
Area sensors for safety.
Aluminium extrusion enclosure with acrylic sheets.

SPECIAL PURPOSE MACHINE'S



Leak Testing SPM For Fuel Tank - KWPG

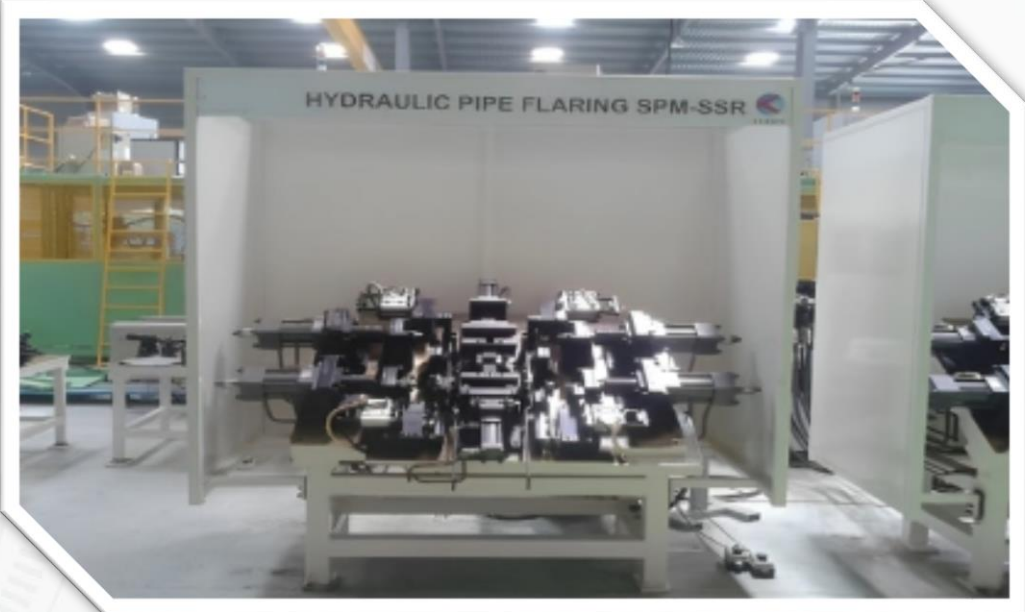

Hydraulic Pipe Flaring

SPECIAL PURPOSE MACHINE'S



Swing Arm Brush Pressing



Stamp Spray Machine

SPECIAL PURPOSE MACHINE'S



Oil & Bearing Seal Press SPM



Toe and Camber Angle checking SPM

SPECIAL PURPOSE MACHINE'S



Automech, Nashik 2WD & 4WD Front Sub assembly station

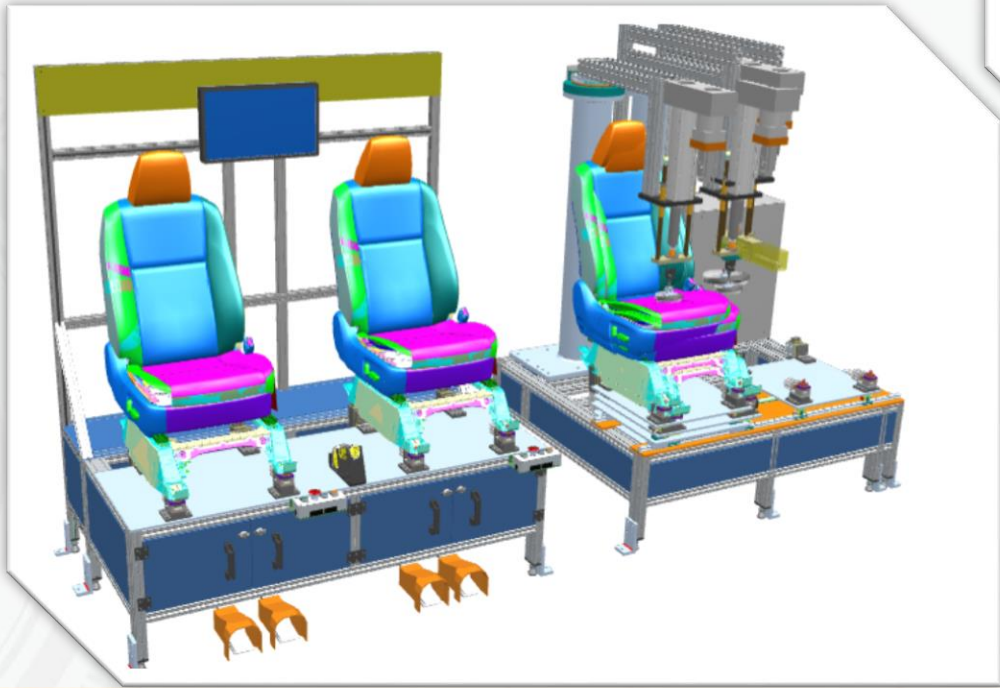
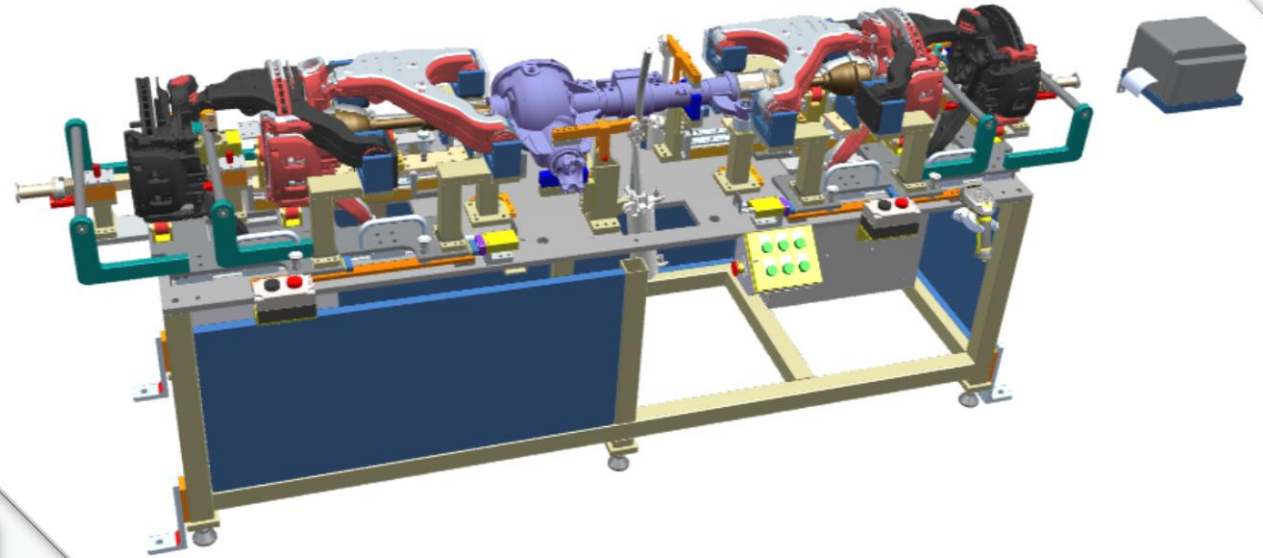

YFG SVS Inspection and Anechoic Chamber

OVERHEAD GANTRY



Overhead gantry & gripper system for Chassis frame handling



OVERHEAD GANTRY



A large, semi-transparent blue rectangular area with rounded corners serves as a background for the main text. It contains a blurred image of an industrial factory floor with robotic arms and machinery. The text is centered within this area.

CATALYTIC CONVERTER ASSEMBLY SYSTEMS

Adaptive canning has become a watchword in the automotive industry as OEMs require increasingly complex catalytic converters to comply with the emission control regulations in different markets. PAPL has developed a range of flexible, automated assembly solutions to help customers keep pace with the changing demands.

SHELL ROLLING FORMING MACHINE

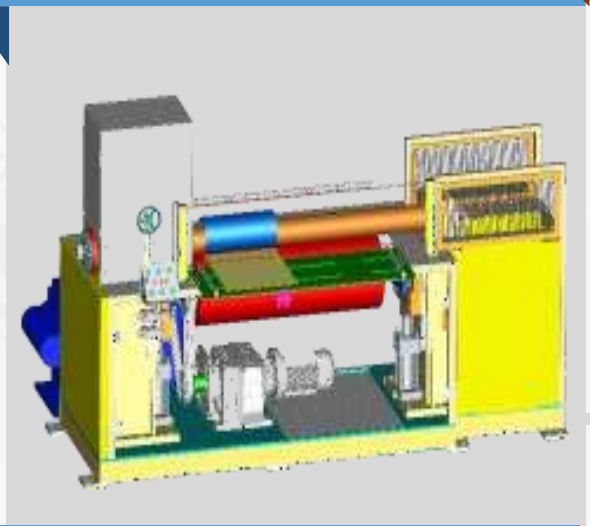

Shell Rolling SPM

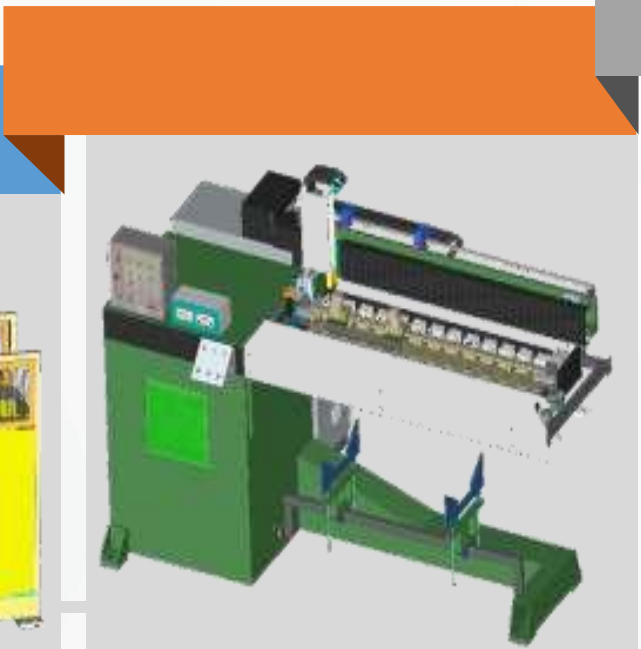

Linear TIG Welding SPM



Tab Cutting SPM



Bead Flattening SPM

CANNING MACHINE



Canning Pressing Machine
Process Poka-yoke
Traceability & Conformity

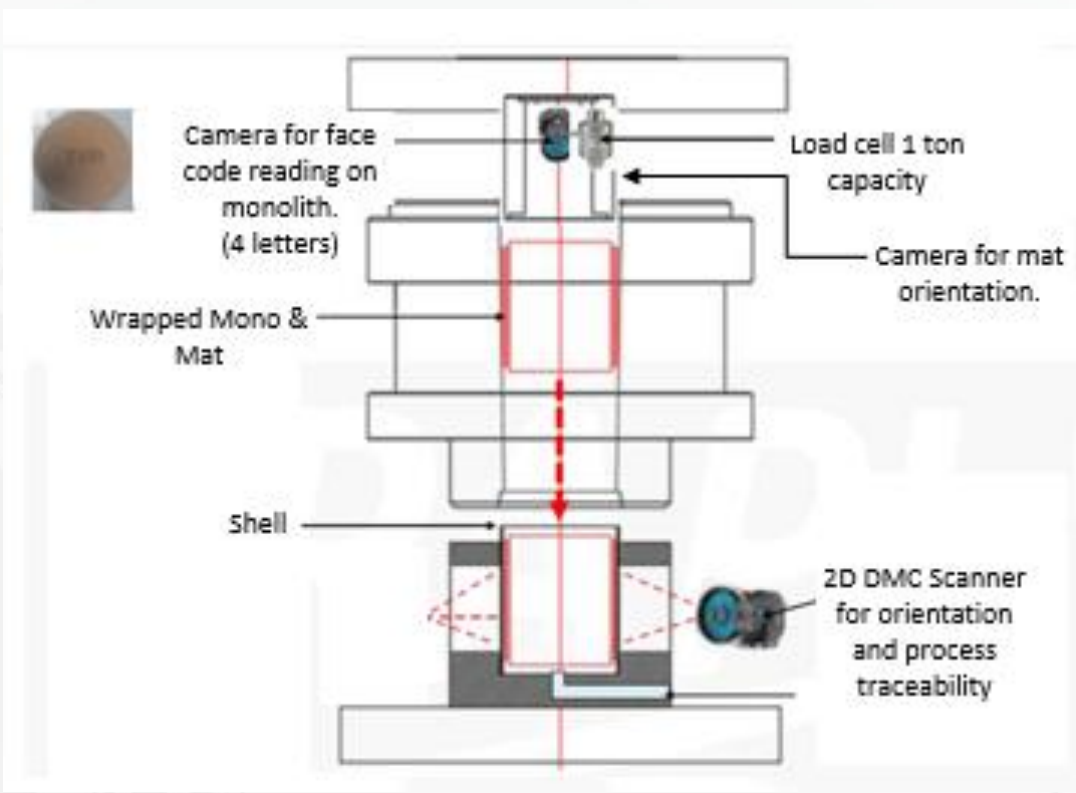

NON - AUTOMOTIVE ASSEMBLY SYSTEMS

Every solution is designed to meet specific customer requirements and PAPL strives to deliver the right fit for a particular market - offering a range of manual, semi-automated and fully automated solutions.

SOLAR PANEL ASSEMBLY LINE



Complete Turn Key scope of Supply for
Automatic Solar Water Heater Panel
Assembly

Trey Pick and Place arrangement

Glass Pick and Place arrangement

Overhead 3 Axis Servo Gantry for Glass

Overhead 3 Axis Servo Gantry for Gluing

Vacuum Gripper - Schmalz

Gluing Unit – Graco

CNC Package - Fanuc

Roller Conveyor with Stopper

Mitsubishi PLC



SOLAR PANEL ASSEMBLY LINE



Complete Turn Key scope of Supply for Elect.
Water Heater Assembly
Pick and Place arrangement
Dome Fitment arrangement
Auto Welding arrangement
Auto Part unloading
Assembly Conveyor



- More than 1450 + Robot integration in a year
- 500+ Welding and assembly SPM in a year
- 600+ Robotic Cell manufacturing in a year
- 85% standardization in design for Robotic cell and Fixturing
- Plant Capacity is 4 Robotic Cell per day i.e. around 1120 Robotic Cell per Year.
- Ensuring round clock service support by having 07Nos service centers in India.
- State of art in-house facility for manufacturing (Approx 80%)

OUR CUSTOMERS

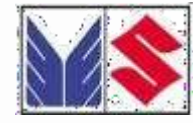





THANK YOU



Patil Automation Ltd.

 **Registered Office & Works:** Gat No. 154, Behind GE Company, Sudumbre, Tal. Maval, Dist. Pune (INDIA) - 412109

 **Corporate Office:** Trident Business Center, Office No.601, Survey No-45. Baner, Pune-411045

 +91 91683 38383  sales@patilautomation.com  www.patilautomation.com